

## DRIVER ASSURANCE

**Mazda Driver's Assurance Plan**  
Check out [www.mymazda.com](http://www.mymazda.com), the website dedicated to you.

Manage your maintenance records, receive valuable offers, see the latest accessories, and much more!

**Mazda Roadside Assistance**

Exhilaration, liberation and inspiration, are great reasons to drive a Mazda car, truck, SUV or minivan. In addition to all the other great standard features, you also get peace of mind, our Emergency Roadside Assistance Plan, it's just a phone call away, 24 hours a day, 365 days a year, call **1-800-866-1998**

**Mazda "bumper-to-bumper" Limited Warranty**

We design and build every Mazda to give you driving pleasure now and far down the road. We're so confident in our quality that we cover the entire vehicle against defects in materials and workmanship

for 48 months or 50,000 miles, whichever comes first

**Mazda Service Transportation Solution**

Being without your Mazda may put a crimp in your day, if you do ever have to take your Mazda in for repairs don't worry, you're covered. With the Mazda Transportation Solution, you will be given a loaner car at no charge when your Mazda vehicle is in for warranty repairs.

For all the details, see your Mazda Dealer

This Quick Tips® guide is provided by Mazda North American Operations to make your Mazda ownership experience more convenient. It is not intended to replace your Owner's Manual.

If you have any questions about your vehicle, you are invited to contact your local dealer. Or if you need additional help, feel free to call our

**Customer Assistance Center at 1-800-222-5500**

Monday through Friday,  
9 a.m.-4:45 p.m., Pacific  
9 a.m.-5:45 p.m., Eastern/Central

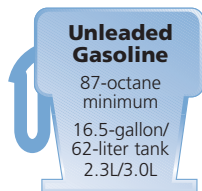

©2005 Calcar, Quick Tips® is a trademark of Calcar, made in USA 7/05 18.588M DOT Mazda North American Operations reserves the right to change product specifications at any time without incurring obligations. 9999-95-014C-06QT

2006

## MAZDA TRIBUTE

### Quick Tips®

Reference  
Guide for  
Controls and  
Functions



## DRIVER'S VIEW

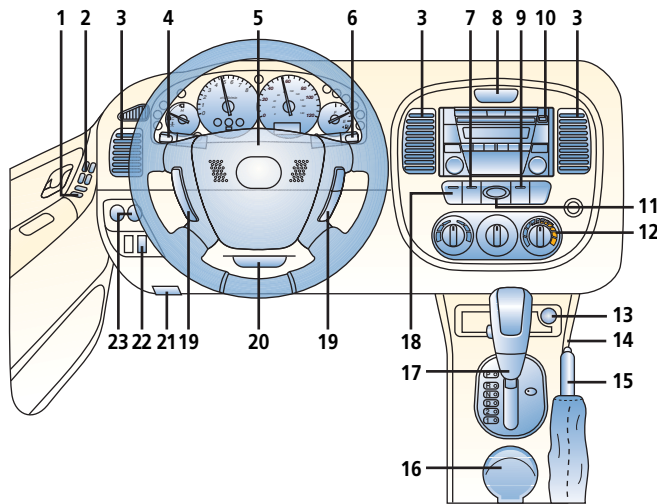





### Getting Started

Tribute Quick Tips® are designed to quickly familiarize you with some important features of your Tribute

This Driver's View tab is your index to the Quick Tips®, locate the item you would like to learn more about and then turn to the listed tab

Be sure to see the tab called Getting Started, this section contains important operating tips about your Tribute

Items identified in blue text call out important information

- |   |   |  |
|---|---|--|
| <p><b>1. Power door locks,</b><br/>see Locks</p> <p><b>2. Power window switches,</b><br/>see Mirrors/Windows</p> <p><b>3. Air vents</b></p> <p><b>4. Turn signals/lighting control lever,</b><br/>see Getting Started</p> <p><b>5. Horn/Air bag</b></p> <p><b>6. Wiper/washer control lever,</b><br/>see Getting Started</p> <p><b>7.  Rear window defogger,</b><br/>see Climate Controls</p> <p><b>8.  Hazard warning switch</b><br/>Push on/off</p> <p><b>9. Air conditioning,</b><br/>see Climate Controls</p> | <p><b>10. Audio system,</b><br/>see Audio Systems</p> <p><b>11. Passenger air bag off indicator,</b><br/>see Getting Started</p> <p><b>12. Climate control panel,</b><br/>see Climate Controls</p> <p><b>13. Auxiliary power point</b></p> <p><b>14. Fuse panel</b></p> <p><b>15. Parking brake lever</b></p> <p><b>16. Cupholder</b></p> <p><b>17. Gearshift lever (A/T)*,</b><br/>see Transaxle</p> <p><b>18.  Fog lamp switch*</b><br/>Press on/off; on with low beams or parking lamps, ignition in ON position, fog lamps deactivate when ignition is in OFF position</p> | <p><b>19. Cruise control*,</b><br/>see Getting Started</p> <p><b>20. Tilt steering-wheel lever</b><br/>Pull release lever down, tilt wheel up or down, push lever up to lock</p> <p><b>21.  Hood release handle</b><br/>Pull to open partially</p> <p><b>22.  Instrument panel lighting</b><br/>To brighten/dim: Press and hold top/bottom of switch</p> <p><b>23. Dual power mirrors,</b><br/>see Mirrors/Windows</p> |
|---|---|--|

\*Denotes optional equipment

Always check the Owner's Manual for more operating information and safety features

Driver's  
View

## GETTING STARTED

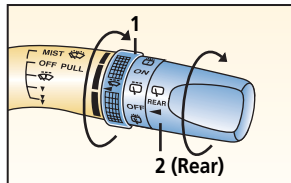
**Front wiper/washer**

Ignition switch must be in ACC or ON position

To activate interval wipers: Push lever down to first detent and rotate knob (1) to desired speed  
 To activate wiper normal or low speed: Push down to second detent  
 To activate high speed: Push lever down to third detent  
 To activate washer: Pull lever toward you  
 To activate mist: Push lever up and release

**Rear wiper/washer**

OFF = Rear wipers off

= To activate rear interval wiper: Rotate knob (2) to first notch

ON = To activate rear normal speed wipe: Rotate knob (2) to second notch

= To activate rear washer: Rotate knob (2) to third notch and release

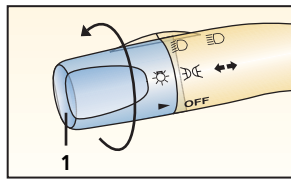
**Turn signal/lighting control lever**

OFF = Lights off

= Tail, side marker, instrument, license plate and parking lights on: Rotate knob (1) to first notch

= Tail, parking, instrument, license plate and headlights on: Rotate knob (1) to second notch

High beams on/off: Push lever forward to detent/pull back to detent

To flash high beams: Pull lever back slightly and release

Turn signals right/left: Move lever up/down

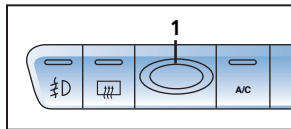
**Passenger Air Bag Off indicator**

Front passenger sensing system is designed to turn off passenger frontal air bag when a low weight is detected, a person of adult size that is sitting properly in the

passenger front seat will enable passenger frontal air bag  
 The sensor also turns off the passenger front air bag and seat-mounted side air bag\* when the passenger seat is empty to prevent unnecessary replacement of air bag(s) after a collision

The front passenger seat-mounted side air bag\* will be deactivated if the sensor detects an empty seat; otherwise, the seat-mounted side air bag\* will be enabled

PASS AIR BAG OFF indicator (1) will be illuminated to remind you the passenger air bag is deactivated

See Owner's Manual for complete details and warnings

**WARNING: If PASS AIR BAG OFF light goes on or off or stays off unexpectedly, please see Owner's Manual for various ways this system may indicate a false reading**

**Cruise control\***

Operates above 30 mph  
 Press and release ON (1)

**To set speed:** Press and release SET ACC (3) at desired speed; hold (3) to accelerate

**To decelerate:** Press and hold CST (4), release at desired speed; or tap brake pedal, press and release (3) at desired speed

**Incremental deceleration:** Press and release (4), each tap = minus 1 mph

**Incremental acceleration:** Press and release (3), each tap = plus 1 mph

**To cancel:** Tap brake/clutch\* pedal or press OFF button (5)

**Return to preset speed (after braking):** Press and release RSM button (2)

\*Denotes optional equipment

Always check the Owner's Manual for more operating information and safety features

## Instrument Cluster

### INSTRUMENT CLUSTER

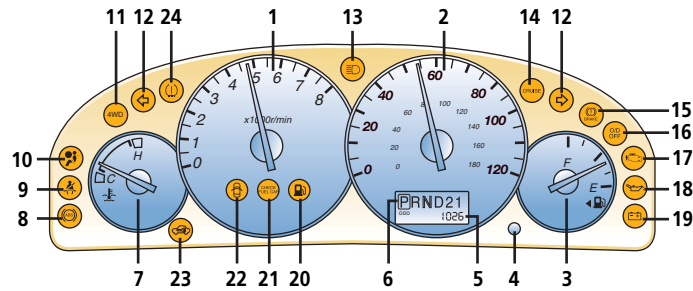

### GAUGES

- 1. Tachometer**
- 2. Speedometer**
- 3. Fuel gauge**  
16.5-gallon/62-liter tank (2.3L and 3.0L)
- 4. Odometer/trip odometer selector**  
Press to toggle between odometer and trip odometer  
**Tip:** Press and hold for more than 1 second to reset trip odometer
- 5. Odometer**
- 6. Gearshift indicator (A/T)\***
- 7. Coolant temperature gauge**  
If above normal range, stop vehicle and turn off engine, check coolant level when safe

### WARNING LIGHTS

- 8. Anti-lock Brake System (ABS)**  
ABS malfunction, normal brakes only, dealer inspection required
- 9. Always fasten safety belts**
- 10. Air bag readiness**  
Front or side air bag malfunction, dealer inspection required
- 11. Four wheel drive indicator\***  
Light blinking continuously indicates 4WD in heat protection mode  
Light blinking intermittently indicates 4WD system disabled, dealer inspection required  
See Transaxle
- 12. Turn signals/hazard warning on**
- 13. High beams on**
- 14. Cruise control on\***, see Getting Started
- 15. Brake system**  
Parking brake on/low brake fluid
- 16. Overdrive off indicator\***, see Transaxle
- 17. Service engine soon**  
Dealer inspection required if light remains on, see Owner's Manual
- 18. Engine oil pressure warning light**
- 19. Charging system warning light**  
Dealer inspection required
- 20. Low fuel**  
Refuel as soon as possible
- 21. Check fuel cap**  
Fuel filler cap not properly installed
- 22. Door ajar**
- 23. Anti-theft on**
- 24. Tire Pressure Monitoring System (TPMS)\***  
Warning light illuminates for a few seconds after ignition is on  
If tire pressure is too high or too low, or tire temperature is too high, warning light will illuminate and beeper will sound  
Flashing warning light indicates possible malfunction; dealer inspection required

\*Denotes optional equipment

Always check the Owner's Manual for more operating information and safety features

Instrument Cluster

LOCKS

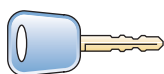

**Key**  
Operates ignition and all locks  
**SecuriLock™ passive anti-theft key**  
Coded chip in key activates ignition

**Tip:** Use key number plate to purchase a new key; store in safe place

**Illuminated entry system\***  
Press UNLOCK or PANIC button on remote entry transmitter, interior lights come on; lights turn off after 25 seconds or with ignition in ON or ACC position

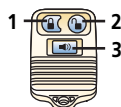

**Remote keyless entry system\***

**1. Lock**  
Press button; pressing again within 3 seconds causes doors to relock, horn to beep

**2. Unlock**  
Press to open driver's door; press again within 3 seconds to open other doors

**Tip:** One step unlocking of all doors, liftgate and liftgate glass is available  
To enable one step door unlocking, press and hold and for 4 seconds, parking lights flash twice; to reset to two step door unlocking, repeat procedure

**3. Panic alarm**

Press , horn sounds; press again to stop, or turn ignition to ON position  
Functions only with ignition in LOCK or ACC position

**Liftgate**

To lock/unlock: Press power door lock button or lock/unlock buttons on Remote Keyless Entry System

To open liftgate window: Pull up on right side lever, located above license plate holder

To open liftgate: Pull up on left side lever

**WARNING:** Cargo and load capacity limited by weight and distribution

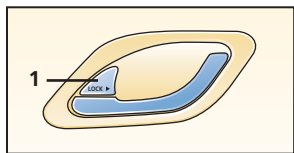

**Manual door locks**  
**1. Lock tab**

To lock: Press lock tab toward front  
To unlock front doors: Pull inside door handle or press lock tab toward back  
To unlock rear doors: Press lock tab toward back

**Smart unlocking system**  
Prevents locking yourself out of vehicle with key in any ignition position; driver's door will automatically unlock if locked using power lock control on driver's door panel when door is open

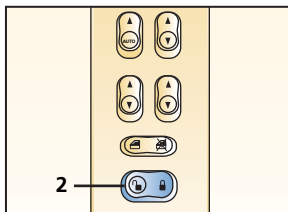

**Power door locks**  
**2. Master front door lock switch**

To unlock/lock all doors: Press / on driver's door switch  
To lock doors without key: With door open, press on driver's door switch, exit vehicle, close doors  
Manual locks override power locks



**Child-safety locks**

Located at the edge of rear doors  
To activate: Rotate knob to   
To cancel: Rotate knob in opposite direction

**WARNING:** Since children may access either rear door, child-safety locks for both rear doors should be activated  
**Never leave a child in car with key in ignition or access to keys**

\*Denotes optional equipment

Always check the Owner's Manual for more operating information and safety features

## Mirrors/ Windows

### MIRRORS / WINDOWS

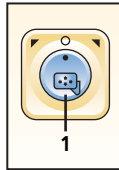

#### Dual power mirrors

To adjust left/right mirror: Rotate control switch (1) left/right, tilt in direction of desired mirror movement

**Tip: To lock mirrors in place, move control switch to center position**

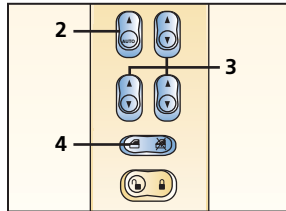

#### Power windows

Operate with ignition in ON position

All windows may be controlled from driver's door; each passenger door has a separate switch

#### 2. Driver's window

One-touch-down: Press rear of switch firmly and release, window goes down all the way; tap switch again to stop; press and hold for

normal operation; press and hold front of switch to close

#### 3. Passenger window switches

Press rear/front of switch to open/close

#### 4. Power window lockout switch

Press right side of switch: only driver's window operates; press left side of switch and all windows function again

**Tip: Power windows and moon roof can be operated for up to 10 minutes after ignition key is turned off and with doors closed, opening door will completely cancel this function**

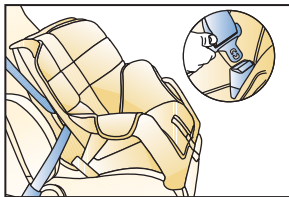

#### Child-safety seat\*

Install in rear outboard passenger seat positions using dual-locking mode retractor safety belts; see Owner's Manual for proper installation and seat tether and LATCH system instructions

**Passenger air bag sensing system**, see Getting Started

**WARNINGS: Use age appropriate child restraints, see Owner's Manual and state or province laws. Never place rear-facing infant-safety seat in front passenger seat in front of any air bag, an infant is in serious danger of being injured or killed.**

**If you must install a forward-facing child-safety seat in the front seating position, move vehicle seat as far back as possible.**

**It is strongly recommended that you install front facing child-safety seats in rear seating area.**

#### Rear child-safety seat anchors

Anchors located on rear seat cushion for securing child-safety seat (see Owner's Manual)

#### Dual locking mode lap/shoulder belt retractor

(front passenger and all rear belts only)

Vehicle sensitive mode:

Belt locks only on hard braking/cornering or impacts of about 5 mph or higher

Automatic locking mode must be used when installing child-safety seat

To activate: Pull webbing fully out of retractor, allow belt to retract until click is heard; belt will only tighten

To disengage: Unbuckle belt and allow webbing to retract fully; for complete details see Owner's Manual

\*Denotes optional equipment

Always check the Owner's Manual for more operating information and safety features

Child-Safety  
Seats

## Seats

### SEATS

#### Beltminder

Intermittently sounds chime and illuminates safety belt warning lamp when driver's safety belt is unbuckled and occupied

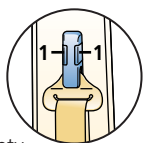

#### Front seat shoulder belt height adjustment

To raise/lower belt: Squeeze and hold release buttons (1) and slide up/down

**WARNING:** Make sure adjuster locks in one of its positions

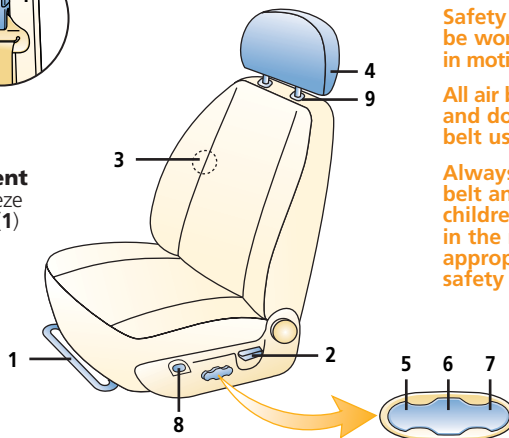

**WARNING:** Do not adjust seats while driving

Safety belts must always be worn when vehicle is in motion

All air bags are supplemental and do not replace safety belt usage

Always wear your safety belt and properly secure children 12 and under in the rear seat, and in appropriate child safety seats

#### Manual controls

##### 1. Fore/aft adjustment

Raise lever and hold, slide seat, release lever

##### 2. Seatback angle/tilt slide seats

To adjust seatback: Lift and hold lever, lean forward or backward to tilt seat, release lever

To slide unoccupied seat: Lift lever to unlock, fold seatback down and slide seat forward

To lock seat: Move to desired position and raise seatback to upright position

##### 3. Manual lumbar adjustment\*

Rotate clockwise/counterclockwise to increase/decrease firmness

##### 4. Head restraint

To raise/lower: Pull up/hold release button (9) and push down

**Tip:** Rear seat head restraints\* can be removed to provide better visibility, rear head restraints\* must be replaced if seats are occupied

##### Power driver's seat\*

##### 5. Raise/lower front of seat

Pull/push front of switch up/down

##### 6. Fore/aft adjustment

Slide entire switch horizontally

##### Raise/lower seat cushion

Pull/push entire switch vertically

##### 7. Raise/lower rear of seat

Pull/push back of switch up/down

##### 8. Heated seats\*

Press to activate/deactivate

##### Folding rear seat, see Owner's Manual

**WARNING:** Never drive with any seat in a reclined position because you will not get the full protection from safety belts

\*Denotes optional equipment

Always check the Owner's Manual for more operating information and safety features

## Seats

## Climate Controls

### CLIMATE CONTROLS

#### 1. Fan speed/recirculated/ outside air control

Rotate knob right: Controls air volume in outside air mode

Rotate knob left: Controls air volume in recirculated air mode

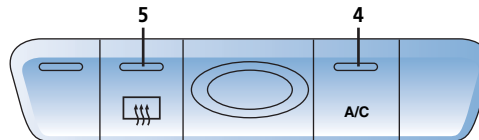

#### 2. Air flow selections

= air to dash

= air to dash and floor

OFF = system off, no air flow

= air to floor

= air to floor and windshield

= defrost, air to windshield

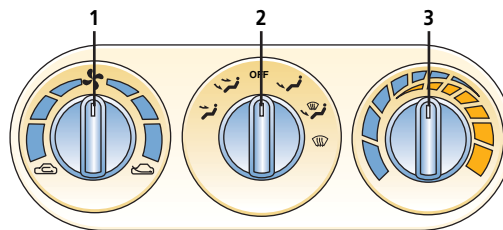

#### 3. Temperature selection

Cooler/warmer = rotate knob counterclockwise/ clockwise

#### 4. A/C

Air conditioning ON/OFF

#### 5. Rear defrost

Press to activate/deactivate, stays on for 15 minutes or until turned off

#### Heated outside mirrors\*

Automatically heated to remove ice, mist and fog when rear defroster is activated

#### Control positions for maximum defrost

Fan to maximum, temperature to maximum hot, air flow selector knob to

**Tips: To prevent moisture buildup, never drive with system off**

**To help prevent windshield fogging in humid weather, select defrost before starting engine**

\*Denotes optional equipment

Always check the Owner's Manual for more operating information and safety features

Climate Controls



RADIO/COMPACT DISC

**1. Power/Volume**

Press to turn on/off; rotate to increase/decrease volume

**2. Disc up ^ †**

Press to skip forward to beginning of previous CD

**3. Disc down v †**

Press to skip back to beginning of previous CD

**4. Memory preset buttons**

To set: Tune to station, press and hold until a beep sound is heard

**5. SEEK/TRACK/APC**

Radio: Press ^ / v to automatically seek higher/lower frequency  
 CD: Press ^ / v to select next/beginning of current track  
 Tape: Press ^ / v to automatically advance tape to beginning of next selection/replay selection; to stop this operation, press button again

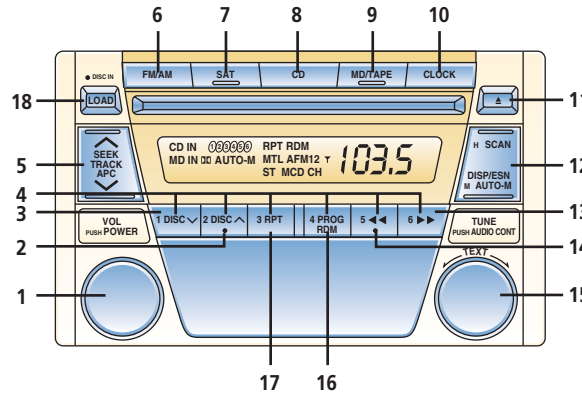

AM/FM/CD Player/Changer\*

**6. FM/AM**

Press to select between FM1/FM2/AM bands and station preset buttons (4)

**7. SAT\***

Satellite ready capability

**8. CD:**

Press to play CD

**9. MD\*/Tape\***

Press to play Mini-disc Player/cassette tape

**10. Clock**

Press and hold (10) until beep sound is heard  
 Press SCAN (12) to adjust the hour  
 Press Auto-M (12) to adjust the minute  
 Press (10) again to set

**11. CD eject button**

**12. DISP/ESN, Scan/Auto-Memory**

SCAN: Press to briefly sample next listenable selections  
 DISP/ESN: MP3/Satellite\* ready capability, view song titles, artist, etc.  
 Auto Memory: Press and hold until a beep sound is heard; system automatically scans and temporarily stores six strong stations in selected band; press again to select from stored stations

**Tip:** If no stations can be tuned, "A" will appear in display

**13. Fast forward ▶▶**

In CD mode: Press to fast forward through a track

**14. Reverse ◀◀**

In CD mode: Press to reverse through a track

**15. Tuning/Audio Control**

Tune: Rotate counterclockwise/clockwise for lower frequency/higher frequency  
 Audio control: Press to select BASS/MID/TREBLE/FADE/BALANCE/BEEP ON/OFF; rotate right/left to adjust selected feature

**16. Program Random**

In CD mode: Press to enable/cancel random play

**17. Repeat**

Press to replay current CD/tape selection

**18. LOAD\***

Press to load single CD, press and hold to load multiple CD's

\*Denotes optional equipment  
 † For use with cassette tape player, MD player, or CD changer\*

Always check the Owner's Manual for more operating information and safety features

## Overhead Console

### OVERHEAD CONSOLE

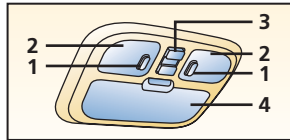

With moonroof

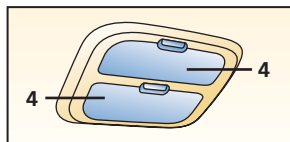

Without moonroof

#### Overhead console\*

##### 1. Map/reading light switches

To turn on/off: Press switch

**Tip:** Map light switches located on dome lamp on vehicles without moon roof

##### 2. Map/reading light

Illuminates whenever any door is opened

##### 3. Moon roof switch\*

To open: Press and hold rear of switch

To close: Press and hold front of switch

To tilt (panel closed): Press and hold front/rear of switch to open/close

##### 4. Storage compartment\*

To open: Press button, then pull to full open position

#### Break-in period

First 1,000 miles: Avoid heavy repeated brake use; avoid full throttle, rapid acceleration or kick-down of transaxle; drive at varying road and engine speeds  
Do not tow a trailer for first 500 miles

Do not use special break-in oils

**Tip:** Follow the same procedures with newly overhauled engine or when brakes are replaced

#### Anti-lock Braking System (ABS)

ABS automatically reduces hydraulic pressure to any wheel on the verge of locking up  
You may feel a slight pulsing of the brake pedal and hear a clicking noise; this tells you the

ABS is functioning properly; increase pressure on pedal for maximum braking

**Tip:** Maintain constant pressure on the brake pedal  
Do not pump the brakes

#### Tire economy and tips

Check pressure monthly when tires are cold

See Owner's Manual for rotation schedule and chart

#### Tire pressure

Decal on driver's door latch pillar provides tire size and pressure information

#### Tire chains\*†

Tire chains can damage aluminum wheels; use on steel wheels only

**Tip:** Use only SAE class "S" chains, install only on front axles if vehicle is 2WD (with P235/70R16 tires) and on both axles if 4WD

Install as tightly as possible and retighten periodically

Never exceed 30 mph with tire chains

#### Spare tire†

Stored underneath the vehicle

#### Jack and tools†

Stored under carpeted hardboard in cargo area, see Owner's Manual

\*Denotes optional equipment

† See Owner's Manual

Always check the Owner's Manual for more operating information and safety features

Driving  
Tips

## Transaxle

### TRANSAXLE

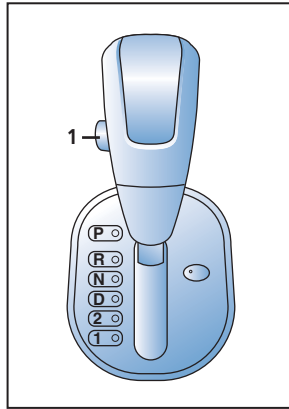

#### Automatic transaxle\*

Gearshift must be in Park or Neutral to start engine; it must be in Park to remove ignition key

#### P = Park

To move gearshift from Park: You must press firmly on the brake pedal and the ignition must be in the ON position

#### R = Reverse

Never engage Reverse when vehicle is moving

#### N = Neutral

No gear is engaged; vehicle can roll freely, even on a slight incline, unless the brakes are applied

#### D (Overdrive)

For normal driving: Transaxle shifts through four forward gears

 **Tip: Torque converter lock-up improves fuel economy and can feel like an additional gear**

#### D (Overdrive Off)

Press the overdrive switch (1) to disengage overdrive; an indicator light on the instrument panel will illuminate

#### 2 = Second

Place the gearshift lever in second when accelerating on slippery roads or to provide additional engine braking on downgrades

#### 1 = First

Provides maximum engine braking on steep downgrades

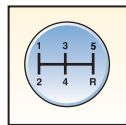

#### Manual transaxle

Depress clutch pedal completely to start engine and change gears

Stop vehicle completely before shifting into reverse

#### Four wheel drive (4WD) system\*†

Your Tribute is equipped with a 4WD system that is always active and requires no driver input, Tribute's intelligent 4WD system monitors vehicle conditions and will automatically adjust power distribution between front and rear wheels, the 4WD system is capable of highway, off-road and winter road conditions

During some extreme off-road events the 4WD system may go into heat protection mode (locked mode), this will help protect the system, to exit heat protection mode, stop vehicle and let it cool down with engine running

\*Denotes optional equipment  
† See Owner's Manual

Always check the Owner's Manual for more operating information and safety features

## Transaxle

## Under Hood

### UNDER HOOD

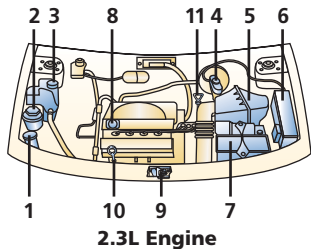

2.3L Engine

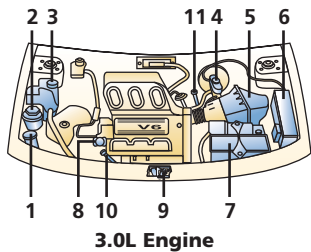

3.0L Engine

#### 1. Windshield washer reservoir

Fill with windshield washer fluid, not water

#### 2. Power steering fluid reservoir

Check with engine off and at normal temperature; fluid level should be within MIN and MAX lines

#### 3. Engine coolant reservoir

Level should be at cold fill level or within the cold fill range when cold

**⚠ WARNING: Never remove coolant reserve tank cap while engine is running or hot; you could get burned**

#### 4. Brake/clutch fluid reservoir

Fill to MAX mark with DOT 3 fluid, check with cap on

#### 5. Air filter

#### 6. Power distribution box

#### 7. Battery

#### 8. Engine oil filler cap

#### 9. Hood latch

#### 10. Engine oil dipstick

Check with engine off and at normal temperature; oil level should be within crosshatched area of dipstick

#### 11. Automatic transaxle fluid dipstick\*\*

Check with engine on at operating temperature; fluid level should be within crosshatched area

### NORMAL SERVICE INTERVALS

5,000 miles*	A
7,500 miles	A
15,000 miles	A B
22,500 miles	A
30,000 miles	A B C
37,500 miles	A D
45,000 miles	A
52,500 miles	A
60,000 miles	A B C E
67,500 miles	A
75,000 miles	A D F
82,500 miles	A
90,000 miles	A C H
97,500 miles	A
100,000 miles	G

**☀ Tip:** For additional service details, see Owner's Manual

### Normal maintenance notes

Change engine oil/replace filter every 5,000\*/7,500 miles; rotate tires every 7,500 miles or sooner if needed; replace cabin air filter every 25,000 miles or 24 months

**A.** Change: Engine oil/replace filter  
Inspect: Engine coolant level, brake fluid level, tire inflation pressure and tire wear, power steering fluid level, washer fluid level  
Lube: Locks and hinges

**B.** Inspect: Disc brakes

**C.** Inspect: Drive belts (3.0 liter), fuel lines and hoses, brake lines, hoses and connections, drum brakes, steering operation and linkages, front and rear suspension ball joints, driveshaft dust boots, exhaust system heat shields, chassis/body bolts and nuts, cooling system and hoses  
Replace: Fuel filter

**D.** Inspect: Drive belts (2.3 liter)

Replace: Air filter

**E.** Inspect: Hoses and tubes

for emission system

**F.** Replace: Spark plugs

Inspect: Engine valve clearance

(2.3 liter), adjust if noisy

**G.** Replace: PCV valve (3.0 liter), engine coolant (yellow)

**H.** Replace: Manual transaxle fluid

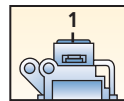

#### Fuel pump shutoff

Disables fuel pump after a substantial

jolt; located in front passenger's footwell, by kick panel access cover  
To reset: Press down top of exposed red reset button (1)

**⚠ WARNING: Do not reset shutoff switch if you see or smell fuel**

\* Special operating conditions  
\*\* Denotes optional equipment

Always check the Owner's Manual for more operating information and safety features